



## ***Your powerful partner at work or at play***

Offering unbeatable versatility, the lightweight F70 will power a wide range of boat types, so it's equally at home when you're working, or if you're out to experience the fresh air and fun of leisure boating and watersports. In fact, the F70 is the lightest, most powerful 4-stroke in its class.

For cleaner performance, maximum fuel efficiency and easy starting, the powerful 16-valve SOHC engine features EFI (Electronic Fuel Injection) and Yamaha's unique PrimeStart™ system. Compatibility with Yamaha's Digital Network Gauges delivers precise control too.

Sleek and stylish too – your F70 is sure to attract admiring glances from everyone – whether aboard or on the shore.

- 16-valve SOHC with EFI (Electronic Fuel Injection)
- Compatible with Yamaha Digital Network Gauges
- Yamaha Customer Outboard Protection (Y-COP)
- Variable trolling RPM switch
- PrimeStart™ system for easy starting
- Efficient blow-by gas reburning system
- RCD (EU 2006) emission rating
- Yamaha's Ideal Anti-corrosion Protection (YDC-30)
- Wide Range Power Trim & Tilt for smooth control
- Simple, quick-connect fresh water flushing device
- Start-in-gear prevention system



***The lightest and  
most powerful  
outboard in its class***

For leisure, pleasure or hard commercial work, the exciting F70 delivers you the perfectly proportioned, lightweight power package.

The very latest Yamaha marine technologies are built into the F70, with revolutionary engine layouts and ingenious intake and exhaust systems. Supreme efficiency is assured by micro-computer controls which monitor every aspect of engine performance, from fuel mixture and combustion efficiency to maintenance scheduling.

A major focus of Yamaha's engine development is on clean-burn technologies that help preserve our environment, yet don't compromise on power, performance or usability.

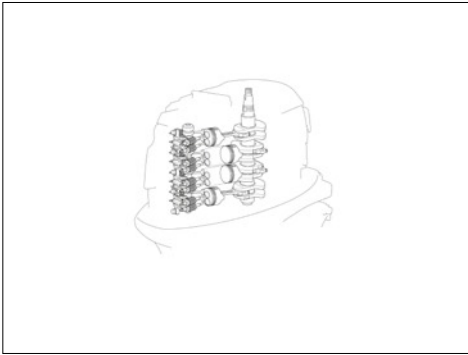

**16-valve, in-line 4 cyl, SOHC, EFI**

The F70's advanced, lightweight powerhead design features a single overhead camshaft (SOHC) with four valves per cylinder, for maximum power and efficiency. A large intake valve area with lightweight pistons and valves give class-leading horsepower-per-litre.

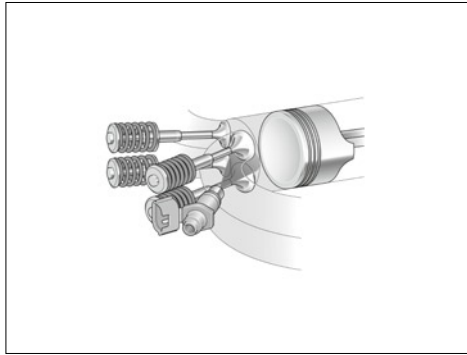

**EFI system for greater efficiency and economy**

Electronic fuel injectors deliver the exact amount of fuel needed for optimum performance and economy. Controlled by the ECM via input from an array of engine sensors, their location just above the intake valves enhances fuel atomisation, resulting in more efficient combustion.



**Yamaha Digital Network Gauges**

The F70 is compatible with Yamaha's Digital Network Gauges, giving you the information needed to maximise engine performance and efficiency, including: a Multifunction Tachometer with RPM, Hours Run, Trim Angle, Oil Pressure, Warning lamps and Variable RPM control; and a Speed/Fuel Management Gauge with Speed, Tank Capacity and Fuel Economy.

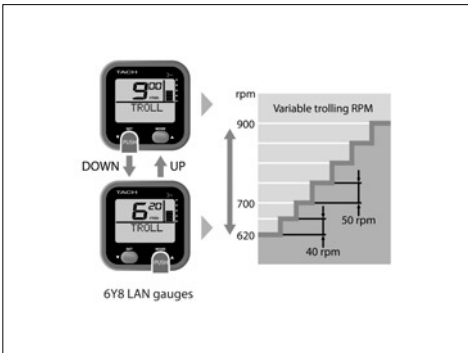

**Variable Trolling RPM control**

With the press of a button on the optional Digital Network's Tachometer – or via the variable trolling RPM switch on the optional multi-function tiller handle – the driver can adjust the engine speed for relaxed trolling, in precise steps of 50 RPM, between 620 and 900 RPM.

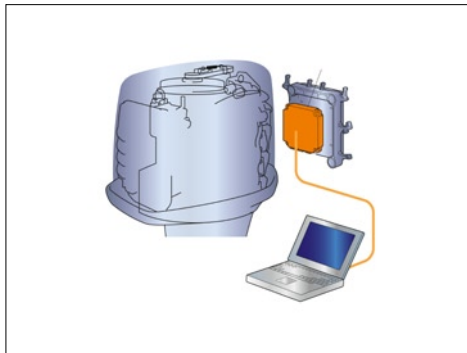

**Micro-computer ECM (Engine Control Module)**

This micro-computer is the 'brain' hidden inside your engine. It constantly monitors data inputs and settings, ensuring smooth running and optimised ignition timings – as well as automatically activating warning lamps and protection systems. A handy computer access port allows an authorised Yamaha dealer to diagnose any problems.

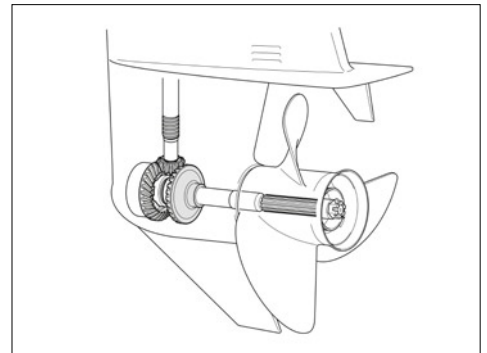

**It's not just fast – it's tough too**

The Yamaha F70 provides outstanding 'out of the hole' acceleration, thanks in part to the lower gearcase design which features a high gear ratio of 2.33:1. The extra toughness comes from the fact that all gears (Forward, Reverse and pinion) are specially hardened for increased durability.

Engine	
Engine type	4-stroke
Displacement	996 cm <sup>3</sup>
No. of cylinders/Configuration	4 cyl./In-line 16-valve SOHC
Bore x stroke	65.0 mm x 75.0 mm
Prop shaft output at mid range	51.5kW / 5,800 rpm
Full Throttle Operating Range	5,300 - 6,300 rpm
Lubrication system	Wet sump
Electronic Fuel Injection	EFI
Ignition / advance system	TCI/Micro-Computer
Starter system	Electric with Prime Start™
Gear ratio	2.33 (28/12)
Dimensions	
Recommended boat transom height	L:508mm X:635mm
Weight with propeller	F70AETL: 119.0 kg, F70AETX: 121.0 kg
Fuel tank capacity	separate, 25 litres
Oil pan capacity	1.9 litres
Additional features	
Steering	Remote Control
Throttle and Shift Controls	Remote Control
Trim & Tilt method (trim angle)	Power Trim & Tilt
Light coil / Alternator Output	12V - 16A with rectifier/regulator
Propeller	Options available
Remark	The kW data in this sheet is based on the ICOMIA 28 standard, measured at the prop shaft



### The Yamaha Chain of Quality

Yamaha technicians are fully trained and equipped to offer the best service and advice for your Yamaha product. For this reason, Yamaha strongly recommends visiting an official Yamaha dealer for all your service requirements. Yamaha Marine Parts & Accessories are especially developed, designed and tested for our Yamaha product range. Yamaha also recommends the use of Yamalube®. Yamalube® is our own range of high-tech lubricants, the lifeblood of Yamaha engines. They are developed to carry on working effectively, no matter where you drive. Besides functional and style accessories, Yamaha offers a range of high quality, innovative boating gear. An extensive range of casual wear is also available. For more information go to: [www.yamaha-motor-acc.com](http://www.yamaha-motor-acc.com)



All information in this catalogue is given for general guidance only and is subject to change without prior notice. Photographs may show boats being driven by professionals and no recommendation or guidance in respect of safe operation or style of use is intended or implied by the publication of these images. Always respect the local maritime regulations. Always wear the recommended personal floatation device and safety equipment when boating.