



## ***For offshore adventures – the ultimate V6 power***

The F225, F250 & F300 outboards represent the pinnacle of Yamaha's latest-generation marine technology. Designed for the demanding offshore environment, these light, compact V6 engines are the ultimate powerhouses to have behind you on your watersports adventures.

For clean, smooth performance, maximum fuel efficiency and easy starting, the advanced 24-valve DOHC engine features EFI (Electronic Fuel Injection) as well as VCT (Variable Camshaft Timing). Combining technology with style, the sleek, compact design speaks for itself.

Meanwhile, at the helm, Yamaha's 'drive-by-wire' electronic throttle and shift delivers the smoothest, most precise control you'll ever experience.

- 24-valve DOHC with Electronic Fuel Injection (EFI)
- Precise digital electronic throttle/shift control
- Digital Network Gauges (conventional and premium)
- Engine synchronisation (twin/triple installations)
- SDS shift dampening system for smooth shift
- Variable trolling RPM
- High output alternator for the engine class (70A)
- Optional Tilt Limiter system
- Y-COP (Yamaha Customer Outboard Protection)
- Meets latest RCD (EU 2006) emission rating
- Wide Range Power Trim & Tilt for smooth control
- Simple, quick-connect fresh water flushing device



***The lightest and  
most powerful V6  
outboards in their  
class***

Whether you're a demanding professional, or simply enjoy your boat on offshore adventures, the exciting F225, F250 or F300 deliver you a perfectly proportioned, lightweight power package.

The very latest Yamaha marine technologies, with their revolutionary engine layouts and ingenious intake and exhaust systems, offer you supreme efficiency, aided by micro-computer controls which monitor every aspect of engine performance, from fuel mixture and combustion efficiency to maintenance scheduling.

A main focus of Yamaha's engine development is on advanced clean-burn technologies, designed without compromising power, performance or usability.

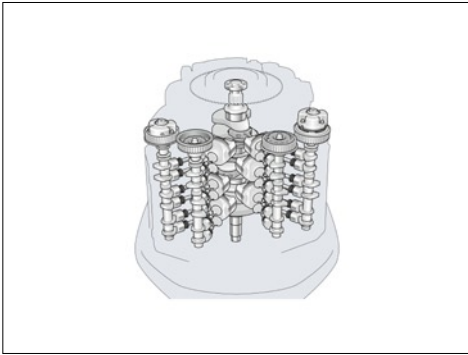

**24-valve, 4.2 litre 60° V6 with DOHC, EFI & VCT**

An advanced, lightweight powerhead design features plasma-fused, sleeveless cylinders, double overhead camshafts (DOHC) and 4 valves per cylinder. Variable camshaft timing (VCT) delivers increased combustion efficiency across the RPM range. This combination of advanced technologies gives class-leading horsepower-per-litre

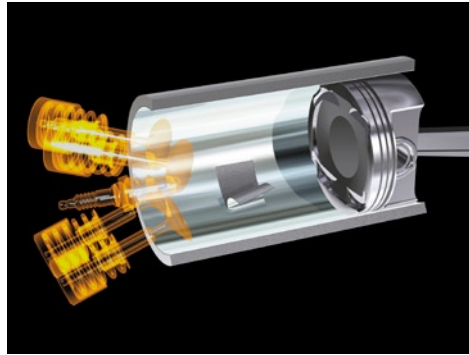

**New cylinder technology**

The Plasma fusion process on the cylinder walls is 60% harder than steel whilst offering lower weight, better cooling and less friction

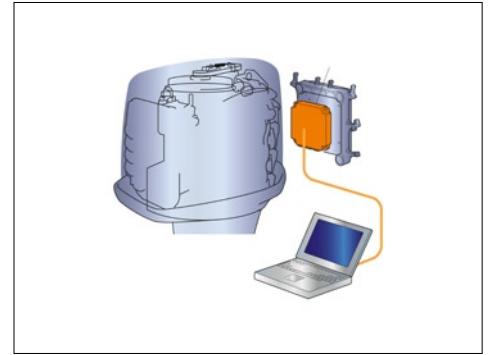

**Micro-computer ECM (Engine Control Module)**

This micro-computer is the 'brain' hidden inside your engine. It constantly monitors data inputs and settings, ensuring smooth running and optimised ignition timings – as well as automatically activating warning lamps and protection systems. A handy computer access port allows an authorised Yamaha dealer to diagnose any problems.

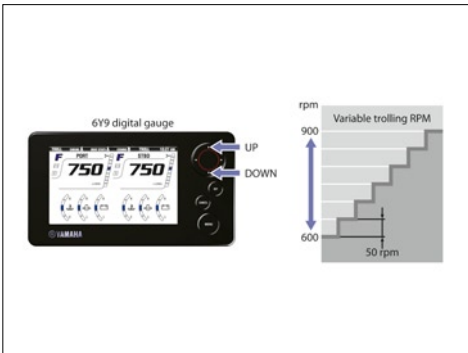

**Electronic 'drive-by-wire' throttle/shift and Trolling RPM control**

The most precise control you've ever experienced, the optional Digital Network System also offers control of engine speed for trolling. A button on the tachometer adjusts the RPM in precise 50 RPM steps, between 600 and 1000. Automatic engine synchronisation in twin/triple installations.



**Digital Network Gauges (Conventional & Premium)**

The F225-F300 are compatible with Yamaha's Digital Network Gauges, which display data to maximise performance and efficiency. A Multifunction Tachometer displays RPM, Hours Run, Trim Angle, Oil Pressure, Warning lamps and Variable RPM control. The Speed/Fuel Management Gauge shows Speed, Tank Capacity and Fuel Economy.

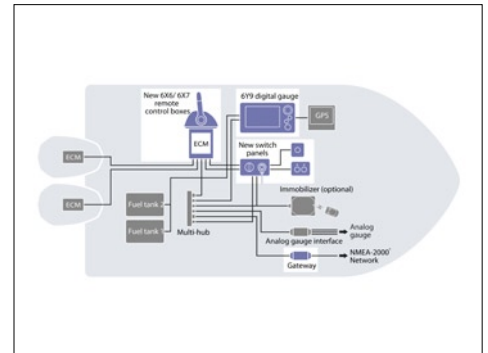

**New Digital Network System II**

The Yamaha Digital Network System II is now available for these engines. It features the new 6Y9 gauges, a high-resolution colour LCD display, a choice of new push button start/stop panels, control boxes, accessories, and an NMEA-2000® gateway. This advanced system can easily be configured for single, double or triple engine applications.

Model	F300B	F250D	F225F
<b>Engine</b>			
Engine type	4-stroke	4-stroke	4-stroke
Displacement	4169 cm <sup>3</sup>	4169 cm <sup>3</sup>	4169 cm <sup>3</sup>
No. of cylinders/Configuration	V6 (60°), 24-valve, DOHC with VCT	V6 (60°), 24-valve, DOHC with VCT	V6 (60°), 24-valve, DOHC with VCT
Bore x stroke	96.0 mm x 96.0 mm	96.0 mm x 96.0 mm	96.0 mm x 96.0 mm
Prop shaft output at mid range	220.7kW / 5,500 rpm	183.9kW / 5,500 rpm	165.5kW / 5,500 rpm
Full Throttle Operating Range	5,000 - 6,000 rpm	5,000 - 6,000 rpm	5,000 - 6,000 rpm
Lubrication system	Wet sump	Wet sump	Wet sump
Electronic Fuel Injection	EFI	EFI	EFI
Ignition / advance system	TCI/Micro-Computer	TCI/Micro-Computer	TCI/Micro-Computer
Starter system	Electric with Prime Start™	Electric with Prime Start™	Electric with Prime Start™
Gear ratio	1.75 (21/12)	1.75 (21/12)	1.75 (21/12)
<b>Dimensions</b>			
Recommended boat transom height	X:635mm U:762mm	X:635mm U:762mm	X:635mm U:762mm
Weight with propeller	F300BETX: 260.0 kg, FL300BETX: 260.0 kg, F300BETU: 268.0 kg, FL300BETU: 268.0 kg	F250DETX: 260.0 kg, FL250DETX: 260.0 kg, F250DEU: 268.0 kg, FL250DEU: 268.0	F225FETX: 260.0 kg, FL225FETX: 260.0 kg, F225 FETU: 268.0 kg
Fuel tank capacity	option	option	option
Oil pan capacity	6.0 litres	6.0 litres	6.0 litres
<b>Additional features</b>			
Steering	Remote Control	Remote Control	Remote Control
Throttle and Shift Controls	Digital electronic remote control, Digital Network II	Digital electronic remote control, Digital Network II	Digital electronic remote control, Digital Network II
Trim & Tilt method (trim angle)	Power Trim & Tilt	Power Trim & Tilt	Power Trim & Tilt
Light coil / Alternator Output	12V - 70A with rectifier/regulator	12V - 70A with rectifier/regulator	12V - 70A with rectifier/regulator
Propeller	Options available	Options available	Options available
Remark	The KW in this sheet is based on the ICOMIA 28 standard, measured at the prop shaft	The KW in this sheet is based on the ICOMIA 28 standard, measured at the prop shaft	The KW in this sheet is based on the ICOMIA 28 standard, measured at the prop shaft



### The Yamaha Chain of Quality

Yamaha technicians are fully trained and equipped to offer the best service and advice for your Yamaha product. For this reason, Yamaha strongly recommends visiting an official Yamaha dealer for all your service requirements. Yamaha Marine Parts & Accessories are especially developed, designed and tested for our Yamaha product range. Yamaha also recommends the use of Yamalube®. Yamalube® is our own range of high-tech lubricants, the lifeblood of Yamaha engines. They are developed to carry on working effectively, no matter where you drive.

Besides functional and style accessories, Yamaha offers a range of high quality, innovative boating gear. An extensive range of casual wear is also available. For more information go to:

[www.yamaha-motor-acc.com](http://www.yamaha-motor-acc.com)



All information in this catalogue is given for general guidance only and is subject to change without prior notice. Photographs may show boats being driven by professionals and no recommendation or guidance in respect of safe operation or style of use is intended or implied by the publication of these images. Always respect the local maritime regulations. Always wear the recommended personal floatation device and safety equipment when boating.