



Just pick up and go – it's your portable power

The F2.5 is a perfect way to get out and enjoy the water, turning even the shortest boat rides into enjoyable adventures.

Inside its neat, streamlined shell, this 4-stroke outboard is packed full of pioneering Yamaha technology. And it packs a punch too – always providing enough power to get you where you want to go. Superb handling, manoeuvrability and reliability on the water come as standard, along with user-friendly controls and vibration-free performance.

The large, comfortable carry-handle makes the F2.5 genuinely portable and a pleasure to use – and adds a new dimension to small boat adventures. It also makes the ideal auxiliary engine for discerning yacht owners.

- TCI Ignition System for ultimate reliability
- Strong tiller handle with twist-grip throttle
- Easy-to-use side shift selector
- F-N (Forward-Neutral) gears for easy control
- Steering friction adjustment for manoeuvrability
- Strong, light handle for comfortable portability
- Two step blow-by gas re-burning system
- Thermostatic water-cooled engine



Technology the World Trusts

Whether you're a recreational boat owner or a busy professional, choose the F2.5 to help you get more out of your boat.

Every engine in the Yamaha range uses the latest Yamaha marine technologies, engine layouts and ingenious intake and exhaust systems. Yamaha's 4-stroke development has been so successful because, rather than just adapting ordinary automotive engines for the water, we design and build our marine-specification 4-strokes from scratch.

Without compromising on power, performance or usability, our specially designed marine engines also help preserve the environment through the use of pioneering clean-burn technologies.

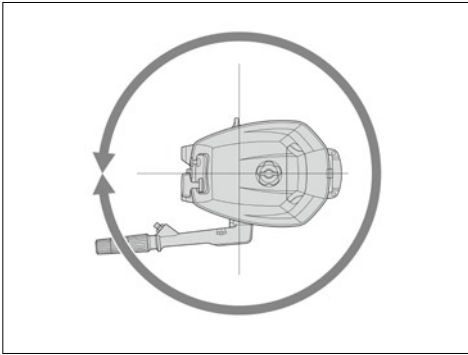

360° steering

Take the F2.5 on to the water and you'll soon appreciate how wonderfully agile it is. Full 360° steering offers exceptional manoeuvrability, making it that much easier to get into tight spots. This also means full reverse thrust is always available without ever having to shift gears.

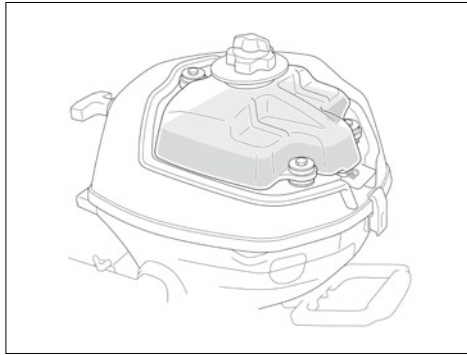

Built-in fuel tank

To really get out there, you need to know you've got room for all the necessary gear, whether that's an extra box of bait, or an extra cooler of refreshments for you and your friends. To give you more space inside your boat, the F2.5 has a built-in fuel tank, eliminating the need for an external equivalent.

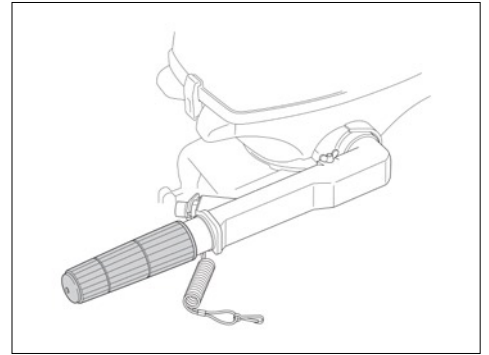

Strong tiller handle with comfortable twist-grip throttle

The F2.5's strong tiller handle, featuring a large and comfortable twist-grip throttle, allows easy control of the engine, while the side-mounted shift selector is also very convenient to use. The result is superb handling and manoeuvrability. The kill switch and throttle cable are integrated into the design.

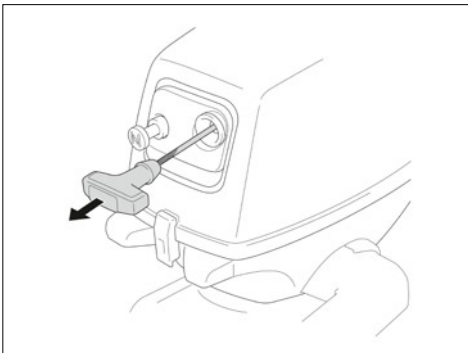

'Start-in-gear' protection

With this kind of power, a false start can be an uncomfortable experience. But Yamaha's 'Start-in-gear' protection eradicates the worry. On Manual Start models, the starter is locked when any gear other than Neutral is engaged.

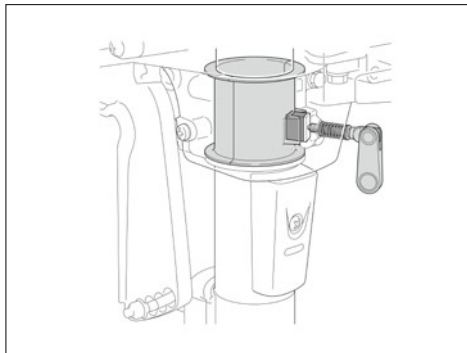

Steering friction adjustment

You'll find the F2.5 incredibly easy to control, thanks to its single-lever steering friction and throttle adjustment. This allows steering and throttle to be easily adjusted when you're out on the water, and ensures that you have great stability and control, even at higher speed.

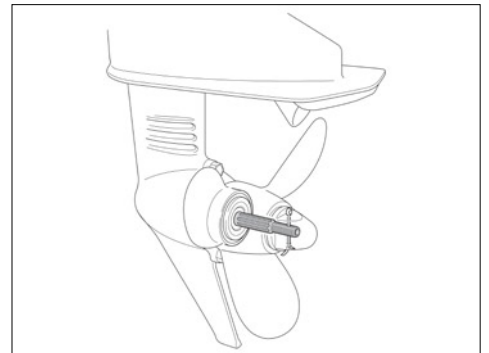

Splined propeller shaft

In keeping with its tough and rugged construction, the F2.5 has a 3-blade alloy propeller secured to the strong gearbox spline by a locking nut.

Engine	
Engine type	4-stroke
Displacement	72 cm ³
No. of cylinders/Configuration	1
Bore x stroke	54.0 mm x 31.5 mm
Prop shaft output at mid range	1.8kW / 5,500 rpm
Full Throttle Operating Range	5,250 - 5,750 rpm
Lubrication system	Splash
Carburettors	1 carb.
Ignition / advance system	TCI
Starter system	Manual
Gear ratio	2.08 (27/13)
Dimensions	
Recommended boat transom height	S:381mm L:508mm
Weight without propeller	F2.5AMHS: 17.0 kg, F2.5AMHL: 17.0 kg
Fuel tank capacity	0.9 litres (Built-in fuel tank)
Oil pan capacity	0.4 litres
Additional features	
Steering	Tiller handle
Throttle and Shift Controls	Tiller handle
Trim & Tilt method (trim angle)	Manual (0°, 4°, 8°, 12°)
Light coil / Alternator Output	-
Propeller	Included
Remark	The kW data in this sheet is based on the ICOMIA 28 standard, measured at the prop shaft



The Yamaha Chain of Quality

Yamaha technicians are fully trained and equipped to offer the best service and advice for your Yamaha product. For this reason, Yamaha strongly recommends visiting an official Yamaha dealer for all your service requirements. Yamaha Marine Parts & Accessories are especially developed, designed and tested for our Yamaha product range. Yamaha also recommends the use of Yamalube®. Yamalube® is our own range of high-tech lubricants, the lifeblood of Yamaha engines. They are developed to carry on working effectively, no matter where you drive. Besides functional and style accessories, Yamaha offers a range of high quality, innovative boating gear. An extensive range of casual wear is also available. For more information go to: www.yamaha-motor-acc.com